



Modbus High Level Interface (HLI)

The VESDA ModBus High Level Interface (HLI) links your VESDAnet¹ with PC software monitoring tools, Building Management Systems (BMSs) or Fire Alarm Control Panels (FACPs), otherwise known as 'host', that support the ModBus protocol.

There are two models available:

- ModBus HLI Type 1 (VHX-0400) which echoes each character received on the RS232 link back to the host together with reply message.
- ModBus HLI Type 2 (VHX-0410) which has the echoing function disabled.

Description

One ModBus HLI is used to interface to a VESDAnet. Modbus HLI supports up to a maximum of 40 VESDA detectors on a VESDAnet. The Modbus HLI supports VESDAnet detector zone numbers between 1 to 200. The Modbus HLI divides up the address range into to 7 logical networks. For example the first 30 addresses are considered in network 1, addresses between 31 to 60 are in network 2 and so on.

Smoke and Alarm Levels

The Smoke Level is reported relative to the Fire Alarm threshold where the full scale is 20. For example, if the Fire Alarm threshold is 0.5 %obs/m, a level of 0.1%obs/m is reported as 4. In other words, the Actual Smoke level = (Reported smoke value * Fire1 Threshold) / 20.

The Fire Alarm threshold is reported as the relative sensitivity to 1 %obs/m as follows:

Fire Threshold (%obs/m)	Reported Level
2	50
1	100
0.1	1000
0.02	5000

Faults

All VESDAnet faults are mapped on one or more of the Modbus HLI faults which are listed below

- Head Fault
- Head Fault (Battery and Mains)
- Head Fault (Scanner²), and
- Flow Fault

VESDAnet faults categorised as network faults are mapped onto all zones, whereas zone faults are mapped onto that particular zone.

Features

- Direct access and monitoring of your VESDAnet system.
- Seamless data transfer.
- Easily configured using Xtralis configuring and monitoring software packages.

Listings/Approvals

VESDA HLIs are recommended for monitoring only. They are not approved for use as a primary reporting device.

Information available using the VESDA Modbus HLI

- Detector Type (VLP, VLS, VLC, VLF).
- Fault Status (Head, Battery and Mains, Flow, Scanner²).
- Detector Alarm State (Alert, Action, Fire).
- Smoke Level
- Smoke Bargraph Level
- Detector Alarm thresholds (Alert, Action, Fire)
- Reset Detector
- Isolate Detector
- Start Scan Test²

¹VESDAnet is a propriety communications protocol allowing your VESDA range of smoke detectors, displays, programmers and remote units (collectively known as devices) to communicate with each other on the one network. VESDAnet is a fault tolerant bi-directional protocol. This means that if one direction of communication fails, then your VESDAnet messages are transmitted in the opposite direction.

²VLS only

Dimensions

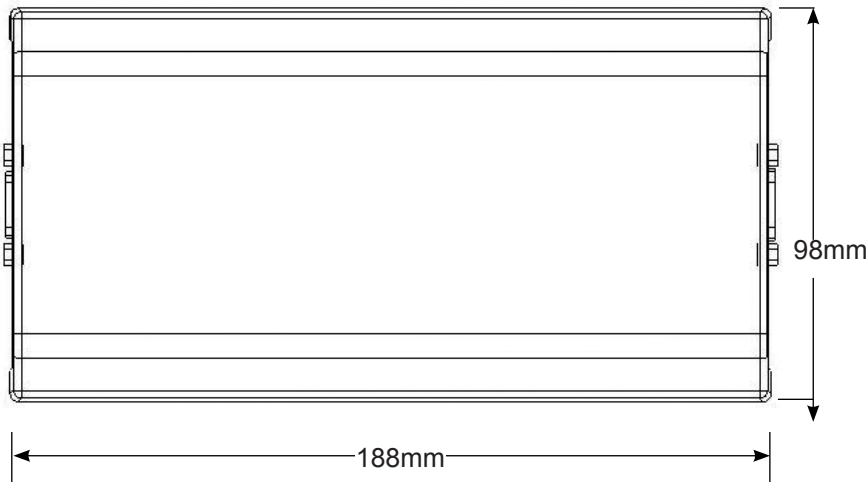

Example VESDAnet system with ModBus HLI

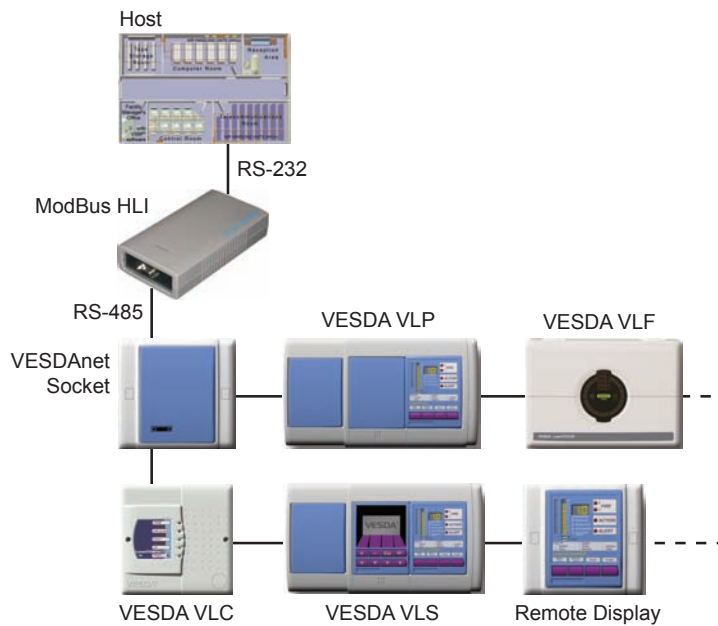

Specifications

Power Consumption:
1.68 W (Quiescent)

Supply Voltage:
24 VDC

Current Consumption:
70 mA (Quiescent)

Dimensions:
188 mm x 98 mm x 40 mm
(7.4 in. x 3.9 in. x 1.6 in. approx.)

Weight:
0.4 kg (0.9 lbs)

Supplied With:
VESDAlink RS-232 9-way serial cable (male-female).
VESDAnet RS-485 15-way cable (male-female)

Number of Detectors Supported:
Up to 200 VESDA Devices (includes max 40 detectors and remaining VESDA ancillary devices)

Modem Support:
Modem support is not available

Product Warranty

2 years

Ordering Information

Product

ModBus HLI - Type 1
ModBus HLI - Type 2
VESDAlink RS-232 9-way serial cable
VESDAnet RS-485 15-way cable

Part number

VHX-0400
VHX-0410
VSP-509 (Spare part)
VSP-511 (Spare part)

www.xtralis.com

The Americas +1 781 740 2223 **Asia** +852 2916 8894 **Australia and New Zealand** +61 3 9936 7000
Continental Europe +32 56 24 19 51 **UK and the Middle East** +44 1442 242 330

The contents of this document are provided on an "as is" basis. No representation or warranty (either express or implied) is made as to the completeness, accuracy or reliability of the contents of this document. The manufacturer reserves the right to change designs or specifications without obligation and without further notice. Except as otherwise provided, all warranties, express or implied, including without limitation any implied warranties of merchantability and fitness for a particular purpose are expressly excluded.

This document includes registered and unregistered trademarks. All trademarks displayed are the trademarks of their respective owners. Your use of this document does not constitute or create a licence or any other right to use the name and/or trademark and/or label.

This document is subject to copyright owned by Xtralis AG ("Xtralis"). You agree not to copy, communicate to the public, adapt, distribute, transfer, sell, modify or publish any contents of this document without the express prior written consent of Xtralis.